

PD0896 2-Speed Close-Ratio Transmission

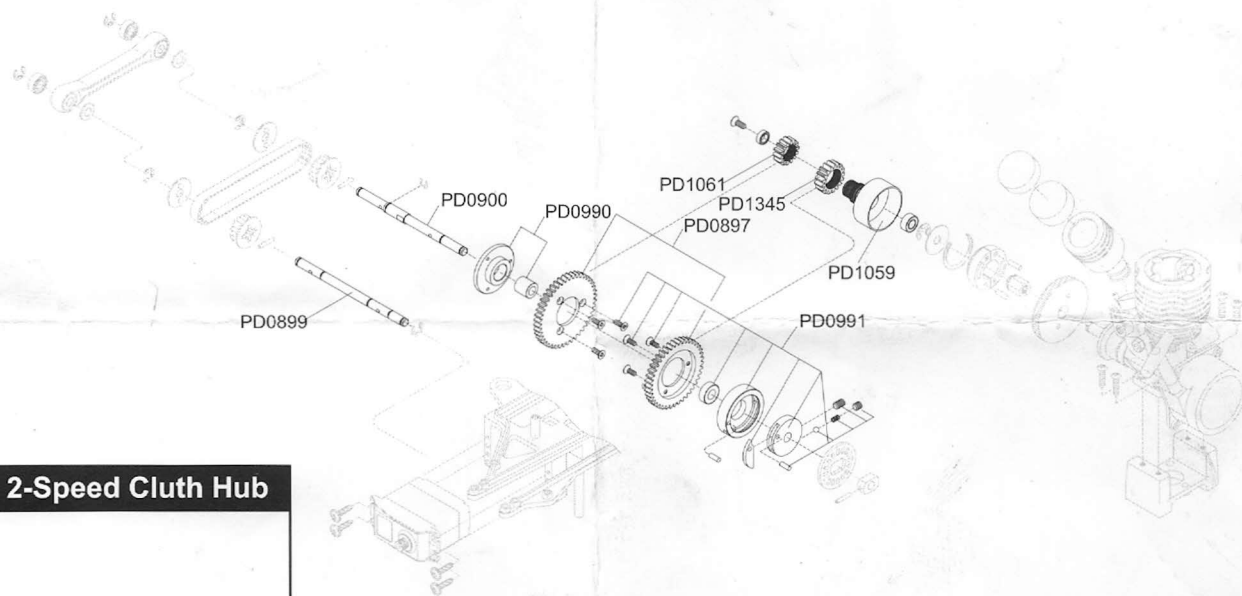

PD0991 2-Speed Cluth Hub

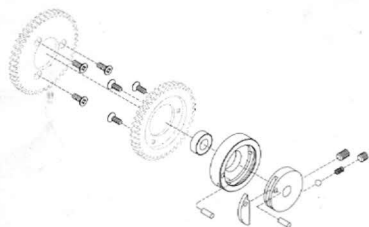

JD6452

TS-4N SERIES 2-SPEED TRANSMISSION

Original pulley, belt, and tension rod.

2-SPEED TRANSMISSION SPARE PARTS:

- PD0897 2-SPEED SPUR GEAR, 41T/44T
- PD1059 2-SPEED CLUTCH BELL
- PD1060 2-SPEED GEAR, 13T
- PD1344 2-SPEED GEAR, 14T
- PD1345 2-SPEED GEAR, 16T
- PD1346 2-SPEED GEAR, 17T
- PD0899 2-SPEED DRIVE SHAFT, FRONT
- PD0900 2-SPEED DRIVE SHAFT, REAR
- PD0990 2-SPEED ONE-WAY (FIRST GEAR) HUB
- PD0991 2-SPEED CLUTCH HUB, HARDWARE

2-SPEED SHIFT POINT ADJUSTMENT

Tighten shift adjust set screw
Shift timing becomes slower
Shifts at higher RPM

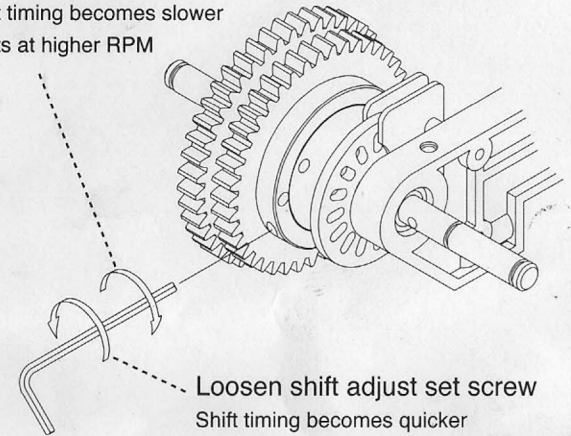

Loosen shift adjust set screw
Shift timing becomes quicker
Shifts at lower RPM

USE THREAD LOCKING GLUE

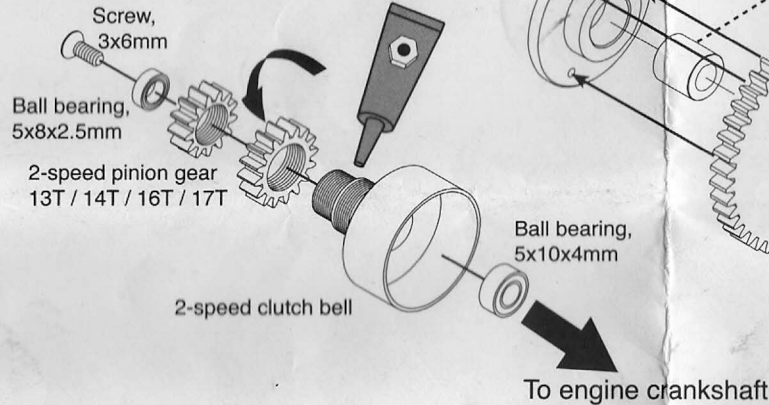

GEAR MESH ADJUSTMENT

Use thin paper to set proper gear mesh.

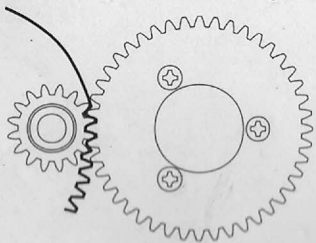

Keep drive shaft and crankshaft parallel

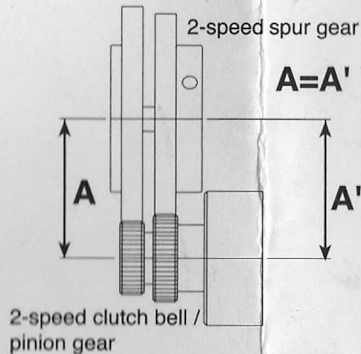

CLUTCH CAM/HOUSING CLEAR VIEW

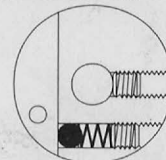

Original brake system, bearing, and rear bulkhead.